



TEXDS Series

Surge Protective Device (SPD)

Installation, Operation & Maintenance Manual



Advanced Protection Technologies
14550 58th St. N.
Clearwater, FL 33760

(800) 237-4567, (727) 535-6339
Fax (727) 539-8955

www.aptspd.com

TRANSIENT  ELIMINATOR[®]



WARNING – IMPORTANT – PLEASE READ – WARNING

Safety First – Hazardous Voltage & Shock Hazard

- Only qualified licensed electricians should install or service SPDs
- Hazardous voltages exist within SPDs
- SPDs should never be installed or serviced when energized
- Use appropriate safety precautions including Personal Protection Equipment
- Failure to follow these instructions can result in death, serious injury, and/or equipment damage.
- This manual shall be read in its entirety prior to installing

Bonding and Grounding Hazard

Verify that the neutral conductor in the service entrance equipment is bonded to ground in accordance with the National Electric Code (NEC®) and all applicable codes.

Verify that the neutral terminal (XO) on the secondary side of distribution transformers are grounded to the system ground in accordance with the NEC® and all applicable codes.

During installation into an electrical system the SPD must not be energized until the electrical system is completely installed, inspected and tested. All conductors must be connected and functional including the neutral (if required). The voltage rating of the SPD and system must be verified before energizing the SPD.

Failure to follow these guidelines can lead to abnormally high voltages at the SPD. This may cause the SPD to fail. The warranty is voided if the SPD is incorrectly installed and/or if the neutral conductor in the service entrance equipment or downstream of separately derived systems is not bonded to ground in accordance with the NEC®.

Do Not Hi-Pot Test SPDs

Any factory or on-site testing of power distribution equipment that exceeds normal operating voltage such as high-potential insulation testing, or any other tests where the suppression components will be subjected to higher voltage than their rated Maximum Continuous Operating Voltage (MCOV) must be conducted with the SPD disconnected from the power source. For 4-wire systems, the neutral connection at the SPD must also be disconnected prior to performing high-potential testing and then reconnected after test completion.

Failure to disconnect SPD and associated components during elevated voltage testing will damage the SPD and will void the warranty.

Table of Contents

INTRODUCTION.....	1
Major Industry Nomenclature Changes Effective 2008-2009.....	1
GENERAL INFORMATION	1
Simplified Explanation of Operation	1
Parallel Connection.....	1
Precautionary Statement Regarding SPDs on Ungrounded Systems.....	1
Unpacking & Preliminary Inspection.....	1
PRE-INSTALLATION & PLANNING.....	2
Operating Environment.....	2
Audible Noise	2
Mounting, Dimensions, and Weight.....	2
Service Clearance.....	2
Cascade Surge Protection.....	2
Maximizing SPD Performance	2
Overcurrent Protection.....	2
Circuit Breaker and Disconnect Switch	2
Terminals.....	2
Wire Size and Installation Torque	3
System Grounding	3
Diagnostic Indication.....	3
Shortest Leads Possible	3
Transient Eliminator	4
Voltage Rating.....	4
Optional Flush Mount Installation Considerations.....	4
Flush Mount Installation Instructions	5
Preferred Installation - Back Flange Mounting.....	5
Alternate Installation - Front Flange Mounting	5
UL 1283 required language concerning the installation of EMI Filters	5
Typical Panel Installation	6
INSTALLATION	6
Common Problems to Avoid.....	6
CONTACT US.....	8
MAINTENANCE	8
Troubleshooting & Service.....	8
Service	8

Figures

2008 NEC Art 285 & UL 1449-3	4
Mounting & Dimensions.....	5
Dry Contacts	6
Flush Mount “/FM”	8
Electrical Drawings for Customer Connections.....	10

Tables

Table 1: Model Number Decoder	7
-------------------------------------	---

INTRODUCTION

Thank you for choosing an APT Surge Protective Device (SPD). This is a high quality, high energy surge suppressor designed to protect sensitive equipment from damaging transient overvoltages.

Proper installation is important to maximize performance. Please follow steps outlined herein.

This entire Operation & Maintenance Manual should be read prior to beginning installation. These instructions are not intended to replace national or local codes. Follow all applicable electrical codes to ensure compliance. Installation of this SPD should only be performed by qualified electrical personnel.

APT SPDs are extensively tested in accordance with industry standards such as ANSI/IEEE C62.41.1, C62.41.2, C62.45, C62.62, C62.72, UL 1449, UL 1283, IEC 61643, etc.

This SPD is a single-port parallel-connected device intended for service entrance, panelboard or downstream installation for IEEE Category C, B or A applications

Major Industry Nomenclature Changes Effective 2008-2009

Be aware that UL 1449 Third Edition and 2008 NEC® Article 285 generated substantial changes.

- The term TVSS changed to SPD
- Types 1, 2, 3 & 4 SPDs are created
- UL 1449 clamping voltage performance testing changed from 500A to 3,000A
- UL 1449 added new I nominal testing (In), which consists of more rigorous duty-cycle testing

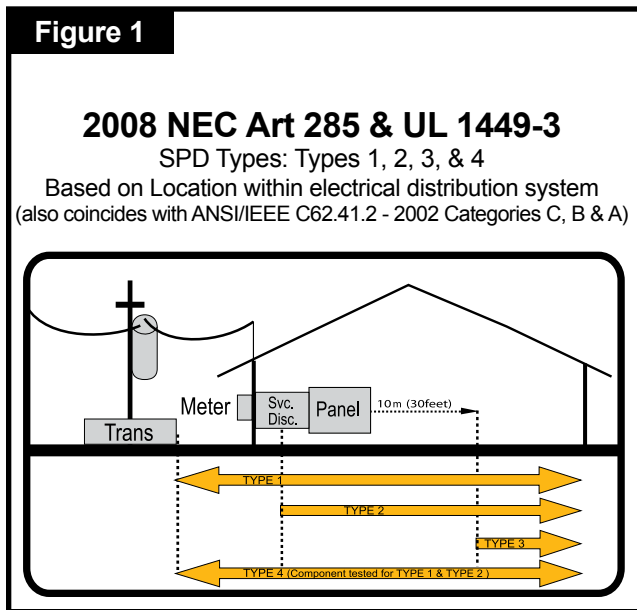

This SPD complies with the latest regulatory actions and is UL Listed as such.

For further information, please review latest editions of NEC® Art. 285, UL 1449 or contact APT Tech Support at (800) 237-4567

GENERAL INFORMATION

This is a Type 1 SPD. Type 1 SPDs include internal overcurrent protection and have been evaluated by UL to more stringent requirements. Type 1 SPDs are suitable for installation on the line side or load side of the service disconnect overcurrent device. (cUL models are Type 2 due to different cUL criteria.)

This device features internal overcurrent and overtemperature protection that will disconnect effected surge suppression components at the end of their useful life, but will maintain power to the load – now unprotected. If this situation is undesirable for the application, follow these instructions for servicing or replacing the device.

Service of this unit consists of replacing it or factory service. There are no user-serviceable parts inside the replaceable module. Do not attempt to disassemble the unit as it stores charge.

Simplified Explanation of Operation

SPDs sense overvoltage and create a momentary short circuit to redirect harmful surge energy to earth ground. Then they reset automatically and wait for the next surge. This is similar to the pressure relief valve on a water heater: pressure goes up, valve opens to relieve pressure and then resets. In an electrical system, an SPD senses overvoltage, shorts temporarily sending energy to ground and then resets. SPDs are capable of repeating this function thousands of times.

Parallel Connection

This is a Parallel connected SPD – not series connected. As outlined above, an SPD ‘drains off’ excessive voltage from an electrical system. Because of parallel connection, installation of the SPD anywhere near the equipment to be protected is satisfactory. This effect is similar to flushing any toilet in a house; pressure in the shower goes down. In an electrical system, a parallel connected SPD will remove excessive voltage off the entire system (assuming reasonable proximity).

Tip: It is critically important that wiring leads be configured as short & straight as possible. Avoid long leads. Avoid sharp bends. Route SPD conductors in the same conduit. Leads do not have to be sized for the entire load – this SPD is parallel connected, not series connected. As a generalization, 8 AWG works fine on this product.

Precautionary Statement Regarding SPDs on Ungrounded Systems

Caution – Ungrounded systems are inherently unstable and can product excessively high line-to-ground voltages during certain fault conditions. During these fault conditions, any electrical equipment including an SPD, may be subjected to voltages which exceed their designed ratings. This information is being provided to the user so that an informed decision can be made before installing any electrical equipment on an ungrounded power system.

Unpacking & Preliminary Inspection

Inspect the entire shipping container for damage or signs of mishandling. Remove the packing materials and further inspect the unit for any obvious shipping damages. If damage is found and is a result of shipping or handling, immediately file a claim with the shipping company and forward a copy to APT.

Storage Environment

This SPD should be stored in a clean, dry environment. Storage temperature range is -40°C (-40°F) to +60°C (+140°F). Avoid exposure to high condensation.

PRE-INSTALLATION & PLANNING

Operating Environment

The standard unit is in a Type 4X enclosure. Before installing, ensure that your enclosure type and application are appropriate per NEMA 250 with regard to moisture, dirt, excessive dust, flammable materials or atmospheres, corrosive vapors, etc.

This SPD is designed in an ambient temperature range of -40°C (-40°F) to +60°C (+140°F) with a relative humidity of 0% to 95% (non-condensing). Excessive temperature may inadvertently operate internal thermal overtemperature protectors.

Audible Noise

SPD background noise is negligible or non-existent, and does not restrict the location of installation.

Mounting, Dimensions, and Weight

This SPD is designed to be wall or chase nipple mounted. The standard enclosure is: 6" x 6" x 4" (152mm x 152mm x 102 mm) (L/W/H) and weight is 5 lbs (2.3 kg). See Figure 2 below.

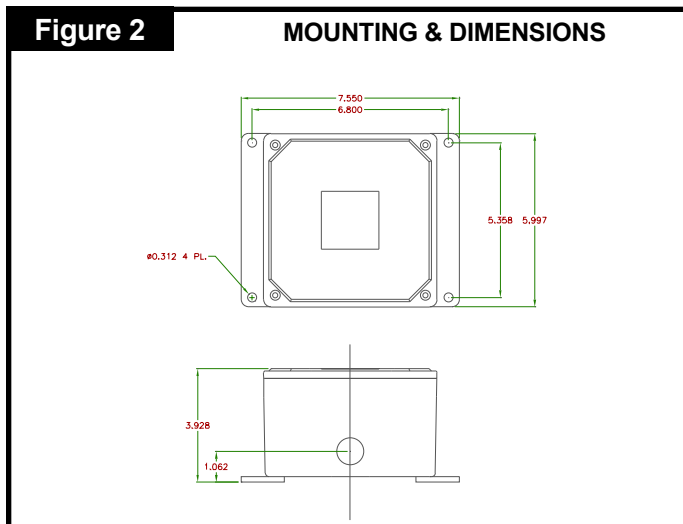

Service Clearance

Service clearance is needed at the front of the TE Series unit only, 36 inches minimum is the required distance for clearance pursuant to the NEC®.

Cascade Surge Protection

For optimum surge protection, cascade or staged surge suppression should be implemented at the service entrance and downstream locations as appropriate. Known or expected surge sources, as well as sensitive loads, should also have localized surge suppression. For interconnected electronic loads (data cabling), SPDs should also be utilized to protect the devices on either end of the interconnecting data cables.

Maximizing SPD Performance

SPD's must be located as close to the circuit as possible to minimize parasitic losses. Surges are high current, high frequency events that cause substantial voltage drops across conductors. This hurts SPD performance. Use the shortest & straightest possible leads. Pre-Plan installations and ensure that nearest breaker positions are used. If new construction, adjust breaker locations as appropriate.

Tip: Voltage drops for normal 120V or 277V lines might be 2-3V per hundred feet. In surge applications, voltage drops might be 100-150V per foot. These voltage drops add to clamping voltage, thus hurting performance. Make every effort to keep leads short and straight.

As distribution gear becomes larger, shorter leads are more difficult to accomplish. When longer leads are unavoidable, gently twist leads together (one to two twists per foot), or tie-wrap leads together.

Tip: surges create magnetic fields per the 'right-hand rule'. When current goes in direction of thumb, magnetic field is in direction of curl of fingers. As surge current goes to SPD, fields are created in one direction. When the SPD sends those currents to neutral and/or ground, current goes in the opposite direction. If 'coming & going' are on the same axis, the magnetic fields can be cancelled, thus avoiding performance decrease. Gentle twists, bundling & tie-wraps accomplish this.

Overcurrent Protection

SPDs draw very little current under normal conditions and conduct for a brief duration upon encountering a transient surge current. This SPD contain internal overcurrent and overtemperature protection to protect against abnormal voltage conditions.

Supplemental overcurrent protection is not required to protect this SPD. However, connecting conductors require protection in Type 2 or 4 applications. Follow applicable codes.

Circuit Breaker and Disconnect Switch

This XD family SPD is tested and qualified as a Type 1 SPD per UL 1449 Third Edition and 2008 NEC. This SPD can be installed on the line side of the service overcurrent device per 2008 NEC Article 285. As a generalization, it is more practical to install on load side of main overcurrent device for maintenance reasons.

When connected on load side of main disconnect, we suggest connecting via a 50-30A circuit breaker. The circuit breaker is the intended disconnect switch and provides short circuit protection to the connecting conductors. The XD Series has internal overload protection elements within the product. A breaker or disconnect is not required for the SPD's overcurrent protection. XD SPD's have demonstrated 200kA Short Circuit Current Ratings (SCCR). 120V & 120/240V XD's have demonstrated 100kA SCCR's. Confer to label on unit.

Terminals

Terminals will accept 14 - 8 AWG conductor and are provided for line (phase), neutral (if used), and equipment safety ground connections. 8 AWG is the minimum recommended wire size because UL testing and evaluation was performed using 8 AWG.

Wire Size and Installation Torque

This is a parallel-connected SPD; it is not series-connected. The size of the SPD wiring is independent of the ampere rating of the protected circuit. Recommended wire is 8 AWG for phase, neutral and ground connections. Torque connections to 18 inch-pounds. Conductor length should be as short as possible.

If other wire sizes are used, we recommend that all conductors be the same gauge. Note that larger conductor might appear to be beneficial; however, it tends to have the same inductance as smaller conductor and is more difficult to work with.

Terminals accept 14 - 8 AWG conductor with 8 AWG being preferred. Coordinate conductor size and overcurrent protection per applicable codes.

System Grounding

An equipment grounding conductor must be used on all electrical circuits connected to the SPD.

For the best performance, use a single point ground system where the service entrance grounding electrode system is connected to and bonded to all other available electrodes, building steel, metal water pipes, driven rods, etc. (for reference see: IEEE Std 142-2007).

For sensitive electronics and computer systems, we recommend that the ground impedance measurement be as low as possible. When metallic raceway is used as an additional grounding conductor, an insulated grounding conductor should be run inside the raceway and sized per the NEC. Adequate electrical continuity must be maintained at all raceway connections. Do not use isolating bushings to interrupt a metallic raceway run.

A separate isolated ground for the SPD is NOT recommended. Proper equipment connections to grounding system and ground grid continuity should be verified via inspections and testing on a regular basis as part of a comprehensive electrical maintenance program.

On 4-Wire Power Systems, neutral to ground bonding (Main Bonding Jumper) must be installed per the NEC®. Failure to do so WILL damage SPDs.

Diagnostic Indication

Phase indicator LEDs (Green)

Each phase is equipped with a Green LED. Should complete loss of surge protection occur on each phase, the Green LED will extinguish and the Red Service LED will flash. Every suppression element is monitored. Note that the Green LED indicators will drop out due to loss of power or severe under voltage.

Service LED (Red)

Flashes in the event of a problem. The Red Service LED is slaved to the Green LEDs via logic and will illuminate when any Green LED extinguishes.

Audible Alarm Option

If equipped with optional Dry Contact and Audible Alarm, these options are slaved via logic to the Green LEDs. In the event of a problem, the dry contacts will change state and the audible alarm will sound. The audible alarm may be silenced by deenergizing the SPD.

Dry Contact Option

One set of Form C dry contacts are included with the Dry Contact option. Dry Contacts change state during inoperative conditions, including loss of power. Any status change can be monitored elsewhere via Dry Contacts.

A Terminal Block includes two sets of Normally Open (N.O.) and Normally Closed (N.C) contacts. This is shown in Figure 3.



A typical application using a Normally Closed configuration would connect to one set of the N.C. and Common terminals. During an inoperative condition, the SPD's dry contact would change state from normally closed to open. We generally suggest the Normally Closed configuration because it will detect a wiring defect, such as cut wire(s), where N.O. will not.

Please note:

Dry Contacts are designed for low voltage or control signals only.

Maximum switching current is 5A

Maximum switching voltage is 240V DC or AC.

Higher energy applications require additional relay implementation outside the TVSS.

An optional Remote Monitor accessory is available to provide visual and audible status. The Remote Monitor will consume the set of Dry Contacts.

Remote Monitor Accessory Option

A Remote Monitor is available for remote annunciation. It requires a standalone 120V power source (wall plug transformer) and uses one set of Form C dry contacts. The Remote Monitor can be configured to monitor several APT SPDs simultaneously. Installation is detailed in a separate document. Contact factory as appropriate.

Shortest Leads Possible

- Leads must be as short and straight as possible - See NEC Art. 285.12
- Pretend wire is \$1000 per foot coming out of your pocket.
- No long leads
- No sharp bends
- No wire nuts
- How short is short enough? As short as you can make it.
- How long is too long? If anyone else can make it shorter.

Voltage Rating

Before installing SPD, verify that it has the same voltage rating as the power distribution system. Compare the SPD's nameplate voltage or model number and ensure that SPD configuration matches the intended power source. See Table 1.

The specifier or the user of the device should be familiar with the configuration and arrangement of the power distribution system in which any SPD is to be installed. The system configuration of any power distribution system is based strictly on how the secondary windings of the transformer supplying the service entrance main or load are configured. This includes whether or not the transformer windings are referenced to earth via a grounding conductor. The system configuration is not based on how any specific load or equipment is connected to a particular power distribution system.

480V System Example: SPDs should be installed per the electrical system, not per a load or motor's wiring connection. For example, a 480V three phase motor might appear to be connected as a 480V Delta. In actuality, the serving distribution system might be a 480Y/277V grounded Wye, with or without a neutral pulled to the motor or MCC. The system is still a 480Y/277V Wye, even though the load is connected as a Delta. A grounded Wye has a defined reference to ground (i.e., neutral is bonded to ground). Some Delta systems are ungrounded, which have no reference to ground and are known to become unstable in certain situations. Such instability can cause line to ground voltage fluctuations that may prematurely fail SPDs. For this reason, the NEC Article 285 has placed SPD restrictions on ungrounded systems. As generalizations, SPDs for ungrounded systems can be installed on grounded systems with a clamping performance penalty. However, SPDs for grounded systems installed on ungrounded systems are almost certainly destined for premature failure. Call APT Tech Support at (800) 237-4567 for further information.

TABLE 1: MODEL NUMBER DECODER

Do not create model numbers from this chart as all features are not available on all models

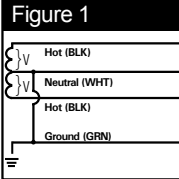
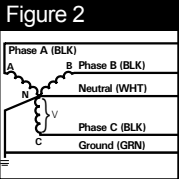
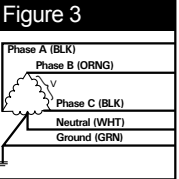
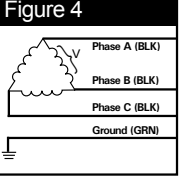
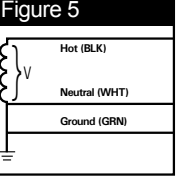
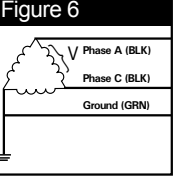
TE	02	XDS	20	4X	A
Transient Eliminator					
Voltage Code for Electrical System		Model Family		Options	
<p>Common North American Systems:</p> <p>01 = 240/120V Split Phase - 1Ø, 3W+Grnd, (Fig 1) 02 = 208Y/120V Wye - 3Ø 4W+Grnd, (Fig 2) 03 = 240/120V High Leg Delta (B High), (Fig 3) 04 = 480Y/277V Wye - 3Ø 4W+Grnd, (Fig 2) 05 = 480V Delta - 3Ø 3W+Grnd, (Fig4) & HRG Wye 08 = 600Y/347V Wye - 3Ø 4W+Grnd, (Fig2)</p> <p>Other Available Systems - Confirmation encouraged:</p> <p>15 = 254/127V Split Phase - 1Ø 3W+Grnd (Fig 1) 18 = 480/240V Split Phase, or Two legs of Wye (Call) 21 = 220Y/127V Wye - 3Ø 4W+Grnd (Fig 2) 41 = 520Y/300V Wye - 3Ø 4W+Grnd (Fig 2) 42 = 415Y/240V Wye - 3Ø 4W+Grnd (Fig 2) 43 = 400Y/230V Wye - 3Ø 4W+Grnd (Fig 2) 44 = 440Y/250V Wye - 3Ø 4W+Grnd (Fig 2) 51 = 480V B Corner Grnd Delta, 3Ø 3W+Grnd (Fig 6) 06 = 240V Delta - 3Ø 3W+Grnd (Fig 4) 61 = 240V B Corner Grnd Delta, 3Ø 3W+Grnd (Fig 6) 07 = 380V/220V Wye - 3Ø 4W+Grnd (Fig 2) 09 = 600V Delta - 3Ø 3W+Grnd (Fig 4) & HRG Wye (Available: 50kA, 100kA) 91 = 600V B Corner Grnd Delta, 3Ø 3W+Grnd (Fig 6) (Available: 50kA, 100kA) 11 = 120V Single Phase (Fig 5) 12 = 240V Single Phase (Fig 5) - Not split phase 13 = 127V Single Phase (Fig 5) 14 = 300V Single Phase (Fig 5) 16 = 277V Single Phase (Fig 5) 17 = 480V Single Phase (1 Hot, 1 Neu, 1 Grnd) (Fig 5)</p>		<p>XDS = External Mount SPD Standard Modes</p> <p>Surge Current Rating</p> <p>10 = 100kA/Phase 15 = 150kA/Phase 20 = 200kA/Phase</p>		<p>A = Audible Alarm & Dry Contacts, Form C, 240V, 5A</p> <p>Type 2 SPD Bearing cUL Mark</p> <p>Delete Options</p> <p>L = Delete L-N Protection (reduces kA rating) G = Delete L-G Protection (reduces kA rating) N = Delete N-G Protection (reduces kA rating) J = Delete Noise Filter</p> <p>Enclosure Rating</p> <p>4X = NEMA 4X Non-Metallic (size 6"x6"x4")</p>	
<p>Figure 1</p>  <p>SPLIT 2 Hots, 1 Neu, 1 Grnd</p>		<p>Figure 2</p>  <p>WYE 3 Hots, 1 Neu, 1 Grnd</p>		<p>Figure 3</p>  <p>HI-LEG DELTA (B High) 3 Hots, (B High), 1 Neu, 1 Grnd</p>	
<p>Figure 4</p>  <p>DELTA & HRG WYE 3 Hots, 1 Grnd</p>		<p>Figure 5</p>  <p>SINGLE POLE 1 Hot, 1 Neu, 1 Grnd</p>		<p>Figure 6</p>  <p>CORNER GROUND DELTA (B grounded) 2 Hots, 1 Grnd</p>	

Optional Flush Mount Installation Considerations

The XD is approximately 4" deep. The unit will not mount flush unless there is at least 4" of depth clearance. The XD is not designed to mount flush on a typical 2x4 stud wall.

Back Flange Mounting: Mount as close as possible to protected panel. Create a wall opening slightly larger than 6 3/4" tall x 6 1/16" wide. See drawing. Configure a robust backing plate inside the wall cavity 3 15/16" from the wall

face such that the SPD is supported from its back. Note the mounting holes on the back flange. Also note that the XD weighs 5 lbs. Be careful not to drop the SPD into the wall.

Flush Mount Installation Instructions

Caution: The chassis of the XD unit can fall into the wall cavity if the four screws attaching the faceplate to the chassis are removed. Use caution not to drop the unit into the wall during installation or service.

The XD unit is approximately 4.0” deep. The unit will not mount flush unless there is at least 3.75” of clearance. The unit is designed to mount flush on a typical “2 x 4” stud wall with drywall.

Depending on the depth of the wall cavity, there are two installation procedures. **The preferred installation utilizes Back Flange Mounting.** The back flange supports the weight of the XD unit and service procedures are greatly simplified. If this can not be accomplished, an alternate Front Flange Mount is possible. Please note that the front flange installation may create servicing difficulties in the future.

Preferred Installation - Back Flange Mounting

Mount as close as possible to the protected panel. Create a wall opening approximately 6 3/4” tall by 6 1/16” wide. See drawing. (Rotate dimensions 90° as appropriate depending on orientation.) Configure an appropriate backing plate inside the wall cavity 3 3/4” from the wall face such that the unit will be supported from its back. Note the mounting holes on the back flange attachments. Be careful not to drop the unit into the wall. Configure electrical conductor and conduit connection consistent with the installation instructions on page 6. Preplan connections such that they are completed prior to fastening the unit to the backing plate. Install faceplate/cover prior to energizing and testing the unit.

Alternate Installation - Front Flange Mounting

This method is not preferred for installation as servicing is substantially more difficult. Extra care should be taken to NOT

DROP the XD unit into the wall. Mount as close as possible to the protected panel. Create a wall opening approximately 6 3/4” tall by 6 1/16” wide. See drawing. (Rotate dimensions 90° as appropriate depending on orientation.) Preplan and pre-connect electrical conductor and conduit connections such that they are completed prior to fastening the unit to the wall. Note that removing the four screws attaching the front faceplate to the unit chassis will cause the XD to fall inside the wall.

UL 1283 required language concerning the installation of EMI Filters

a) An insulated grounding conductor that is identical in size and insulation material and thickness to the grounded and ungrounded circuit supply conductors, except that it is green with or without one or more yellow stripes, is to be installed as part of the circuit that supplies the filter. Reference should be made to Table 250-122 of the National Electrical Code regarding the appropriate size of the grounding conductor.

b) The grounding conductor mentioned in item a is to be grounded to earth at the service equipment or other acceptable building earth ground such as the building frame in the case of a high-rise steel-frame structure.

c) Any attachment-plug receptacles in the vicinity of the filter are to be of a grounding type, and the grounding conductors serving these receptacles are to be connected to earth ground at the service equipment or other acceptable building earth ground such as the building frame in the case of a high-rise steel-frame structure.

d) Pressure terminal or pressure splicing connectors and soldering lugs used in the installation of the filter shall be identified as being suitable for the material of the conductors. Conductors of dissimilar metals shall not be intermixed in a terminal or splicing connector where physical contact occurs between dissimilar conductors unless the device is identified for the purpose and conditions of use.

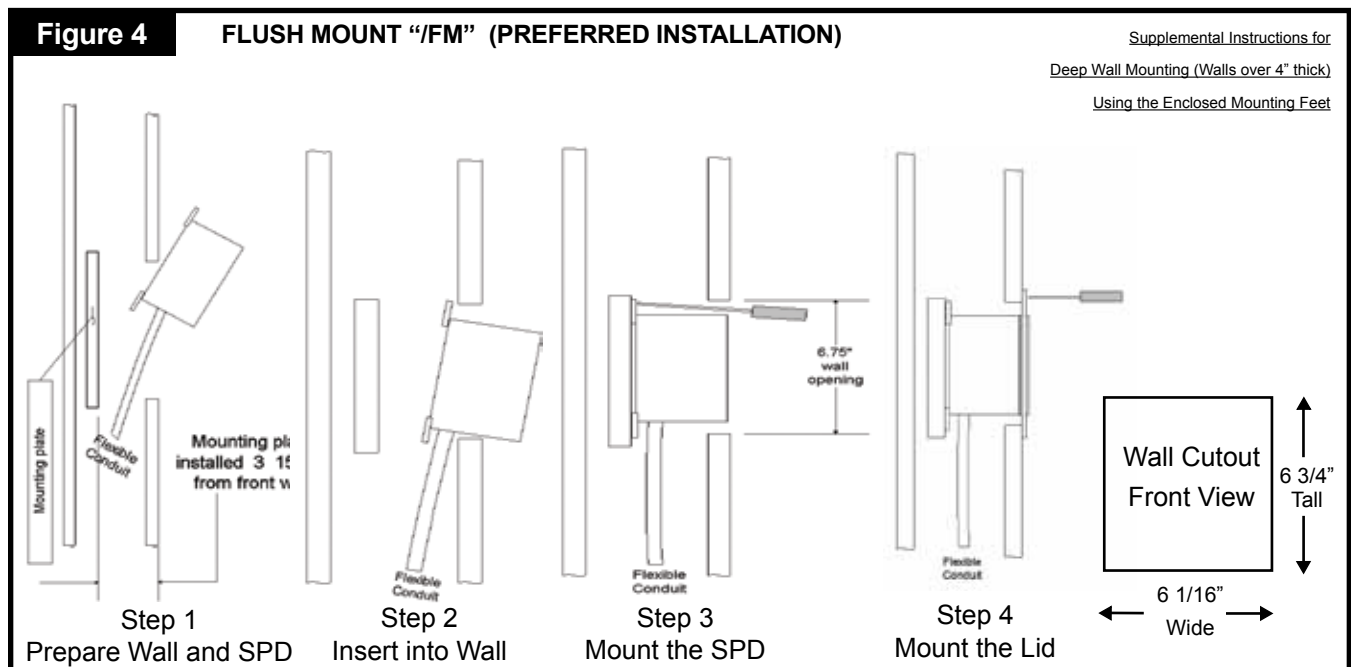

INSTALLATION

Common Problems to Avoid

- Confirm System voltage to SPD voltage (120V SPD will fail instantly on 240V, 277V, etc.)
- Locate SPD close so leads are short & straight as possible (or will seriously hurt performance)
- Make sure N-G or XO bonding meets NEC® (or will prematurely fail SPD)
- Energize SPD AFTER system is stabilized & checked (inadvertent system problem may fail SPD)
- SPDs are regulated by NEC® Article 285 and UL 1449
- Never Hi-Pot test any SPD (will prematurely fail SPD)

Pre-Plan your installation. You will need to accomplish the following:

- Meet all National and Local codes (NEC® Article 285 addresses SPDs)
- Mount SPD as close to panel or equipment as possible to keep leads short
- Ensure leads are as short and straight as possible, including neutral and ground. Consider a breaker position that is closest to the SPD and the panel's neutral & ground
- Suggested breaker & conductor size is 50A-30A with 8 AWG
- Make sure system is grounded per NEC® and clear of faults before energizing SPD.

1. Use a voltmeter to check all voltages to ensure correct SPD
2. If unit has Flush Mount option refer to Flush Mount Installation Instructions following
3. If SPD has Dry Contact pre-plan its installation
4. Remove power for panel. Confirm panel is deenergized.
5. Identify breaker location and SPD location
6. Remove an appropriately sized knockout from panel
7. Mount SPD, use appropriate weatherproofing equipment as needed
8. Connect conductors as appropriate – short and straight as possible (Note that Hi-Legs are Phase B)
9. Label or mark conductors as appropriate (neutral: white, ground: green, energized: black, hi-leg: orange)
10. Make sure system is bonded per NEC® and is clear of hazards or faults before energizing (N-G bonding not per NEC® will fail SPDs: #1 cause of SPD failures)
11. Energize and confirm proper operation of indicators and/or options

A sealing O-ring is provided. SPD can be chase-nipple mounted (nut is provided). Note that any conduits must be installed correctly.

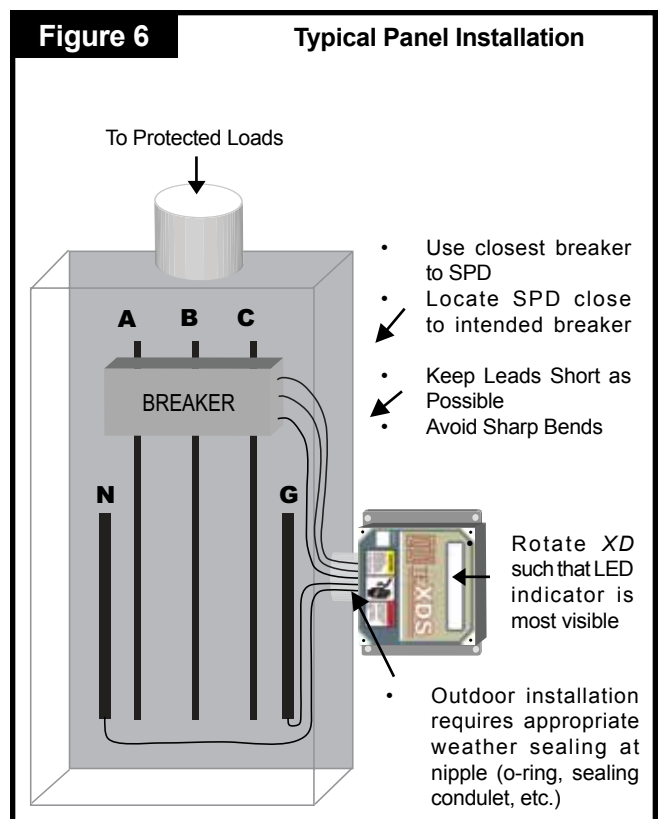
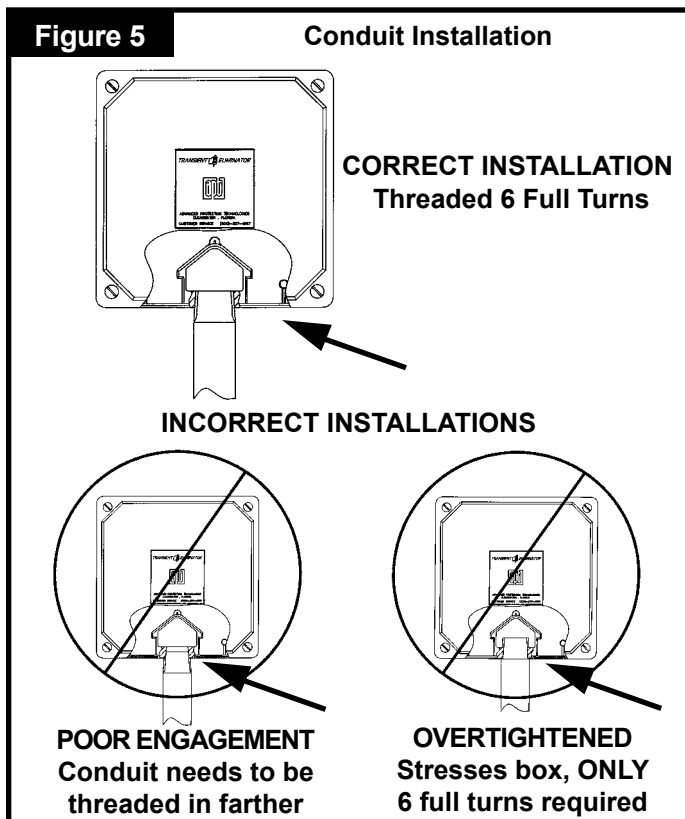
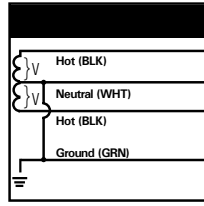

Figure 7

ELECTRICAL DRAWINGS FOR CUSTOMER CONNECTIONS

TWO POLE



SPLIT
2 Hots, 1 Neu, 1 Gmd

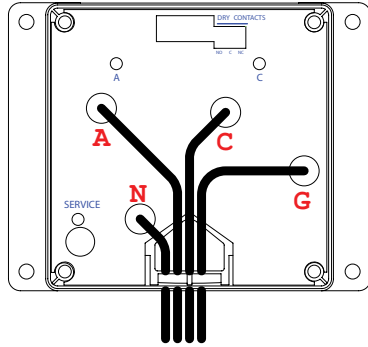

THREE POLE

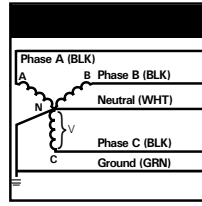

WYE
3 Hots, 1 Neu, 1 Gmd

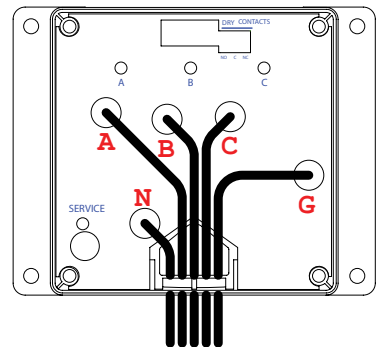

THREE POLE

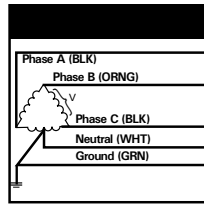

HI-LEG DELTA (B High)
3 Hots, (B HIGH),
1 Neu, 1 Gmd

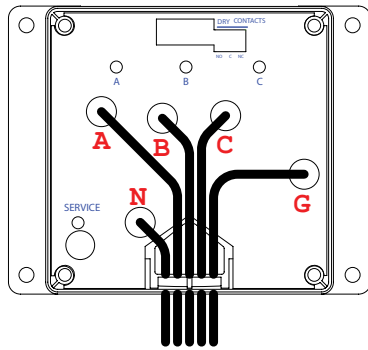

THREE POLE

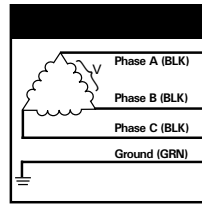

DELTA & HRG WYE
3 Hots, 1 Gmd

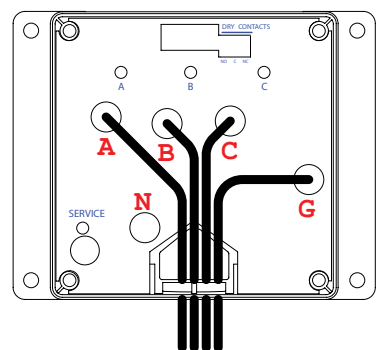

SINGLE POLE

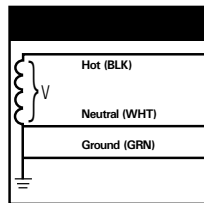

SINGLE POLE
1 Hot, 1 Neu, 1 Gmd

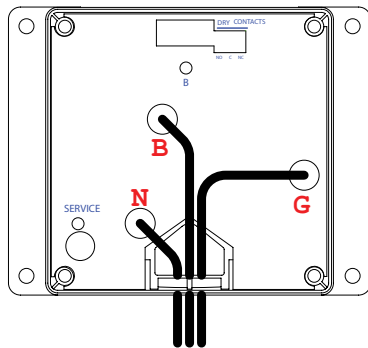

TWO POLE

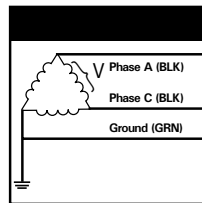

CORNER GROUND
DELTA (B grounded)
2 Hots, 1 Gmd

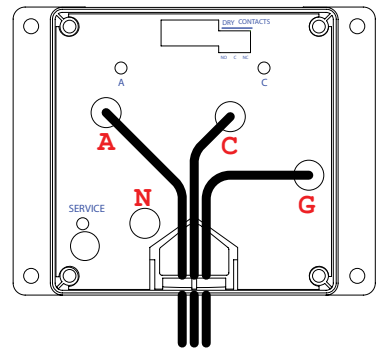

MAINTENANCE

SPDs require minimal maintenance. We recommend periodic inspection of diagnostic indicators to ensure proper operation. We also recommend keeping the SPD clean as appropriate.

Troubleshooting & Service

Please contact us for any service related issues. We want to take care of any problems.

Quality SPDs are designed and tested to withstand severe duty. However, there are various electrical anomalies that SPDs cannot protect against. These are generally Sustained Overvoltages also known as Temporary Overvoltages (TOVs). In this context, Sustained Overvoltages may be only a few cycles. Failed SPDs tend to be symptoms, not root causes. A failed SPD should be treated as a 'canary in the coalmine' suggesting further investigation as there may be a larger issue at play. Regardless of cause, SPDs attempt to protect their load until failure.

As noted above, the single largest 'killer' of SPDs is reference to ground issues. If the SPD shows problems on startup, there is reasonable chance of bonding/grounding/misapplication issue. This permanently damages the unit. If not corrected, it will happen again.

Tip: Visually confirm N-G bonding. Be aware that a voltmeter measuring N-G can be misleading. For example, N-G voltage could read 0V because neutral and ground are at the same potential purely by happenstance, not because they are bonded. Visually confirm bonding.

Tip: Experience indicates that regulation-challenged generators can cause Sustained Overvoltages, as well as ungrounded generators, and/or usual load transfer systems.

Service

There are no user serviceable parts inside. We strongly recommend against disassembly.

Units may be returned to the factory for factory service, qualification and return. Please contact factory at (800) 237-4567 for assistance.

CONTACT US

Advanced Protection Technologies
14550 59th St. N.
Clearwater, FL 33760

(800) 237-4567
(727) 535-6339
Fax (727) 539-8955

www.aptspd.com

Any returns need a Return Authorization number.

UL is a registered trademark of Underwriters Laboratories, NEC and National Electrical Code are registered trademarks of National Fire Protection Association, C62.41.1-2002, C62.41.2-2002, C62.45-2002, C62.72-2007 are registered trademarks of IEEE.

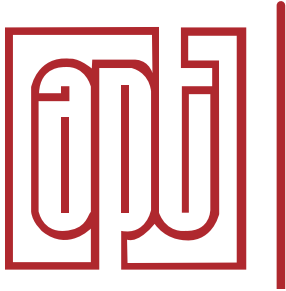

ADVANCED PROTECTION TECHNOLOGIES INC.

“Professionals Serving Professionals”



Advanced Protection Technologies

14550 58th Street North ▪ Clearwater, Florida 33760
(800) 237-4567 ▪ (727) 535-6339 ▪ Fax (727) 539-8955
www.apttvss.com ▪ info@apttvss.com ▪ www.aptspd.com

European Authorized Representative:
Obelis S.A.
Boulevard Général Wabis, 53
B-1030 Brussels
Belgium
Tel.: +32.2.732.59.54 · Fax: +32.2.732.60.02
Email: mail@obelis.net



UL is a registered trademark of Underwriters Laboratories, NEC and National Electrical Code are registered trademarks of National Fire Protection Association, C62.41.1-2002, C62.41.2-2002, C62.45-2002, C62.72-2007 are registered trademarks of IEEE.