

12.1" Panel Computer - PS3650A-T42/T42S Series



Open HMI Option: WinGP

TouchPanel Operation



8 GB or 2 GB Bootable CompactFlash® Card



16-128GB Solid State Drive

12.1-inch TFT Color LCD Panel Computer

PS-3650TA

Models: PS3650-T42/T42S Series,
CPU: Intel Celeron M 1.5 GHz

AC100-240V

24VDC

12.1-inch

XGA

All-in-one model

Windows® XP

Factory Alert System

Windows® XP Embedded

SSD

WinGP

CF Card



Features:

- 12.1-inch (XGA 1024x768) TFT Touch Panel Computer
- Intel® Celeron® M 1.5 GHz
- 250GB Hard Drive, 2 or 8GB CF Drive, 16-128 GB SSD (Solid State Drive)
- Windows XP Pro or Windows XP Embedded
- Integrated Factory Alert System with Output Port*1
- NEMA 4/4x/12 Rated
- SSD (Solid State Drive) for reliability and faster data access

• RoHS Directive-conforming

- **On-demand HMI WinGP Option**
- Use PC as On-demand Touch Screen HMI
- Allows 3rd Party Applications to Run Concurrently:
 - SPC, Vision, SCADA, MRP
- Expands PC Hardware and Data Connectivity Options

Performance Specifications

Model	PS3650A-T42/T42S Series - Build to order (See reverse side for ordering information)	
Supported OS	Windows® XP Multi-language (XM250, XM16SA, XM32SA, XM64SA, XM128SA), Windows® XP Pro* (XPC08) (*This version of XP Pro includes English, French, Spanish, Brazilian Portuguese, Japanese, Simplified and Traditional Chinese Languages), Windows® XP Embedded Multi-language (EM2G)	
CPU	Intel® Celeron® M 1.5 GHz	
Standard Memory	1 GB SO-DIMM	
Maximum Memory	1 Slot (Max. 1 GB) SO-DIMM socket (PC2700)	
Graphics Display Resolution	XGA (1024 x 768 dots)	
Video Memory	Max. 64 MB (When using Windows®) UMA Type	
Display Type and Size	TFT Color LCD (12 inch)	
Display Colors	262,144 Colors	
Display Area	W 245.76mm [9.68in.] x H 184.32mm [7.26in.]	
Touch Screen	Resistive Film (Analog)	
Serial	<PS3650A-T42> COM1: RS 232C, D-sub 9 pin (plug) (422 / 485, RI/+5V switchable) COM2: None	<PS3650A-T42S> COM1: RS 232C, D-sub 9 pin (plug) (422 / 485, RI/+5V switchable) COM2: RS 232C, D-sub 9 pin (plug) (RI/+5V switchable)
LAN	Rear 2 ports. RJ-45 type modular jack connector (8 pins) LAN1: auto change to 10BASE-T/100BASE-TX LAN2: auto change to 10BASE-T/100BASE-TX/100BASE-T (Supports Wake-On LAN)	
USB	USB 2.0 compatible side 4 ports. Disable by hardware setting. USB 1.1 front face port	
Sound	Stereo speaker output, rear 1 port (3.5mm jack)	
Disk	IDE I/F, Master: 2.5 inch 250GB HDD. or 16-128GB SSD Slave: CF Card I/F (not hot-swappable). Switchable to Master by hardware setting.	
PCMCIA	1 Port PCMCIA Type II. Corresponding to CARD BUS (Excluding Zoomed Video, SOUND functions)	
PCI	Rev.2.2 compatible PCI I/F (5V) 1 Port Slot Length: Depth 174.63mm[6.88in.] x Height 106.68mm[4.2in.]	
RAS	<PS3650A-T42> D-Sub, 9-Pin Socket 1 port	<PS3650A-T42S>*1 None

*1 Factory Alert System is equipped without RAS port

General Specifications

Model Numbers	PS3650A-T42/T42S Series (AC Models),	PS3650A-T42/T42S-24V Series (DC Models)
Input Voltage	AC100 / 240V (Rated Voltage AC85 to 264V)	24V DC (Rated Voltage DC19.2 to 28.8V)
Power Consumption	110VA or less	80W or less
Allowable Voltage Drop	1 cycle or less (Voltage drop interval must be 1s or more.)	5ms or less
Voltage Endurance	AC1500V 20mA for 1 minute (between charging and FG terminals)	AC1000V 20mA for 1 minute (between charging and FG terminals)
Insulation Resistance	DC500V 10MΩ(min.) (between charging and FG terminals)	
Certification	UL508, CSA-C22.2 No.142-M1987, CE (EN55011 Class A, EN61000-6-2, EN60950-1), RoHS	UL508, CSA-C22.2 No.142-M1987, CE (EN55011 Class A, EN61000-6-2), RoHS
Temperature	0 to 50°C (32 to 122°F) without HDD; 5 to 50°C (41 to 122°F) with HDD / Storage Temperature -20 to +60°C (-4 to 140°F)	
Humidity - Ambient/Storage	10 to 90% RH (Not condensing, wet bulb temperature: 29°C (84.2°F) or less). / Storage Humidity 10 to 90% RH (Not condensing, wet bulb temperature: 39°C (102.2°F) or less).	
Corrosive Gas	Free of corrosive gases	
Noise Immunity	Noise Voltage: 1500Vp-p, Pulse Duration: 50ns, 500ns, 1µs, Rise Time: 1ns (via noise simulator)	Noise Voltage: 1000Vp-p, Pulse Duration: 50ns, 500ns, 1µs Rise Time: 1ns (via noise simulator)
Cooling Method	Forced Air Cooling by Fan	
Electrostatic Discharge Immunity	6kV (complies with EN 61000-4-2 Level 3)	
Vibration Resistance	Without HDD - IEC61131-2 compliant. 5 to 9Hz single-amplitude 3.5mm, 9 to 150Hz constant-accelerated velocity 9.8m/s ² . X, Y, Z directions for 10 cycle (100 minutes) With HDD - 10 to 57 Hz Single amplitude: 0.0375 mm (0.003in) 57 to 150 Hz Fixed acceleration: 4.9m/s ² . X, Y, Z directions for 10 cycle (80 minutes)	
Rating	Equivalent to IP65f NEMA #250 TYPE 4/4X/12. (Not using front USB)	
Weight	Approx. 4.5kg [9.9lb] (unit only)	
External Dimensions	313mm [12.32in.] W × 239mm [9.41in.] H × 103mm [4.06in.] D	
Warranty	Two (2) year	

PS-3650A - External Dimensions

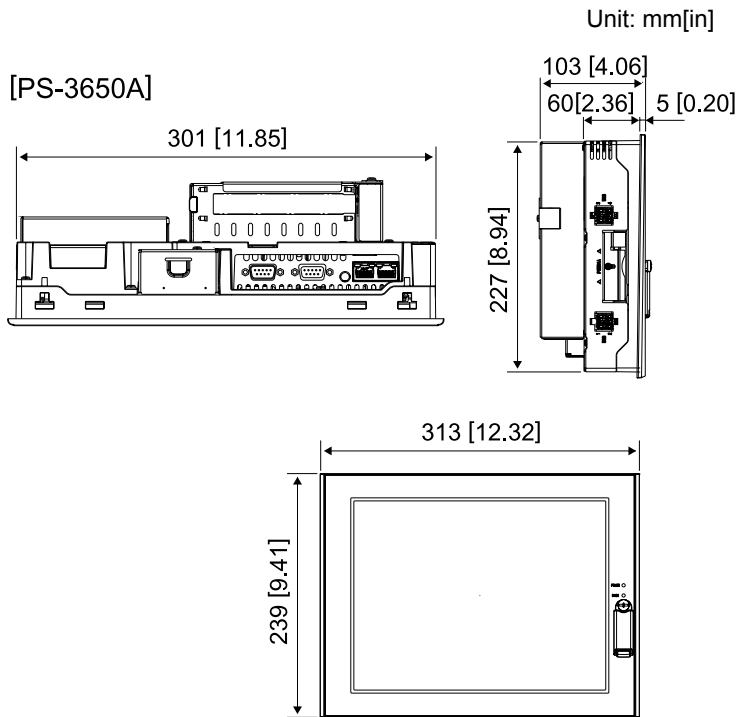

Note: Aluminum Housing

PS-3650A - Cut-Out Dimensions

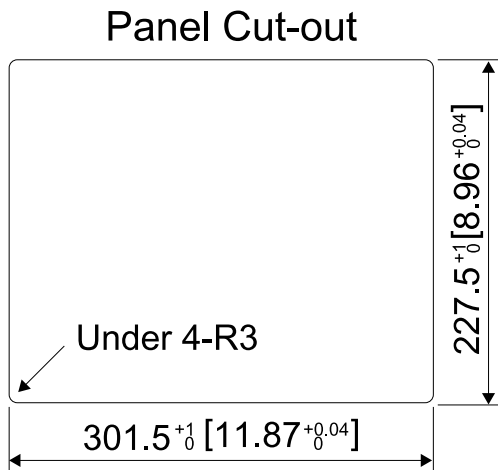

Unit: mm[in]

Ordering Information

PS3650A-T42 - - 1G - - -

Serial port _____
Blank...1 Port
S.....2 Ports

Power Supply: _____
Blank....AC
24V.....DC

Operating System: _____
XM250....250 GB HDD w/ XP ML
EM2G...2 GB CF w/ XP ML
XPC08..8 GB CF w/ XP Pro*
XM16SA..16GB SSDw/XP ML
XM32SA..32GB SSDw/XP ML
XM64SA..64GB SSDw/XP ML
XM128SA..128GB SSDw/XP ML

Secondary Storage _____
Blank.....No Secondary Storage
NO250.....250GB HDD
NO16SA..16GB SSD
NO32SA..32GB SSD

Open HMI: _____
Blank....No HMI Software Included
WG.....WinGP Installed

* The languages included with this version of Windows XP Pro are English, French, Spanish, Brazilian Portuguese, Japanese, Simplified and Traditional Chinese

Optional Items

Product Name	Part Number
SO-DIMM Memory	1 GB PSA-DDR1G
HDD Unit *2	250 GB PS365XA-HD250
CF Card *2	512MB CA3-CFCALL/512MB-01
	1GB CA6-CFCALL/1GB-01
	2GB CA8-CFCALL/2GB-01
	8GB 150638 *3
Installation Gasket*1	CA3-WPG12-01
Installation Fasteners *1	CA3-ATFALL-01
Backlight (2 pieces/set for 1 unit)	CA8-BLU12XGA-01
Screen Protection Sheet (5 sheets/set)	CA5-DFS10-01

*1 Standard attachment for all models. *2 Not installed with operating system. *3 Must be slave if used with another IDE device, otherwise set as master



Pro-face America
Phone: 734.429.4971
Fax: 734.429.1010
www.profaceamerica.com

Customer Service Hotline: 734.944.0482

For more information
ACCESS www.profaceamerica.com

