

AC Power / DIN Rail

Three Phase/ Parallel / 4-Pole

IEC Class II /IEEE Category C, B, A

The AC Power DIN Rail mounted AC Surge Protectors are designed for downstream load protection. These are parallel connected devices, housed in UL 94V-0 thermoplastic enclosures. Each device includes internal thermal disconnects and visual failure mode status indicators with optional relay contacts.



These devices are intended for use in IEC Class II, UL 1449 Type 2, Type 4, and IEEE Category C, B & A load applications.

Branch Applications / Robotics / Automation / AC Power / Communications / Critical Power

Technical Data

Model Series	AC - Power
Suppression Technology	TPMOV®
Surge Current Rating	50kA per mode
Degree of Protection	IP 20 / IP 65
Short Circuit Rating	200,000A rms
Enclosure Material	Thermoplastic V-0
Mounting Type	DIN 3 Rail / 35mm / 1 TE
Conductor Sizing	#6 - #14 AWG
UL Recognized (UR)	Yes - UL1449
IEC / CE Compliance	Yes / 61643-1
IEEE Category Rating	C, B & A
I _{max} (8x20μs)	50kA
I _n (8x20μs)	20kA
Frequency Rating	50/60Hz
Temperature Rating	-40°C to +85°C
Warranty	5 yr

Approval Standards

- RoHS Compliant
- UL 1449 Third Edition
- ANSI/IEEE C62.41
- IEC 61643
- NEMA LS-1
- CE Mark

Application & Ratings

- Type 2, 4 Locations
- Surge Life @ 3kA: 5000 events
- Surge Life @ 10kA: 1000 events

EXTERNAL FUSE NOT REQUIRED

SEPARATE OVERCURRENT PROTECTION IS NOT REQUIRED FOR 200kA SCCR RATING.

Model	D120V3PNG	D127V3PNG	D277V3PNG	D347V3PNG
Voltage	120/208 WYE	127/220 WYE	277/480 WYE	347/600 WYE
MCOV	150V	180V	320V	420V
Modes	L-L, L-N, N-G	L-L, L-N, N-G	L-L, L-N, N-G	L-L, L-N, N-G
UL VPR	600V	600V	2000V	2500V

NOTE: Add "M" to part number for dry contacts

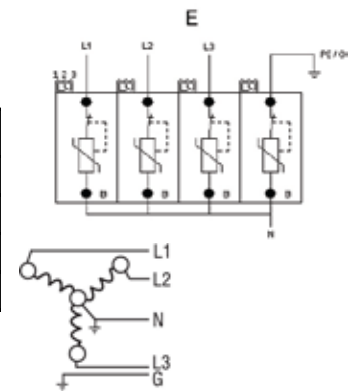

3 Phase Wye
4 Wire + Ground

E103120

APT US

Advanced Protection Technologies



14550 58th Street North
Clearwater, FL 33760
Tel (800) 237-4567
Fax (727) 539-8955
www.apttvss.com

Installation Instructions

Three Pole

- D120V3PNG— 120/208 3 phase WYE
- D127V3PNG— 127/220 3 phase WYE
- D277V3PNG— 277/480 3 phase WYE
- D347V3PNG— 347/600 3 phase WYE

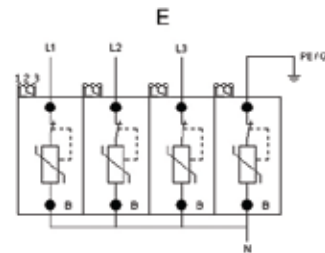
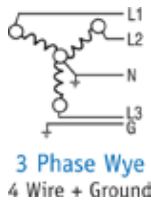

Mounting

APT DIN is designed to mount onto a 35mm DIN rail or top-hat rail (standard EN 50022, BS 5584) set in the horizontal position. To install, first hook the line side over the 35mm DIN rail and then push in the load side until the blue spring loaded mounting clip “clicks” onto the rail with the label text shown in the upright position reading left to right.

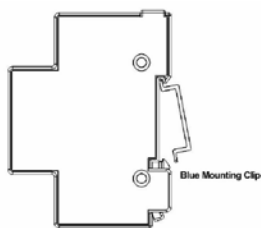

Replacement / Removal

If the blown indicator tab is visible on any of the multiple pole units, then the entire unit has reached the end of its life and must be replaced. To remove, push up on the unit and rock the top off the 35mm DIN rail.

Wiring Installation

#6-#14 AWG, 60/75°C Copper wire shall be used. Maximum torque to be applied to terminal screws is 14.75 in-lb. Strip back wire installation 6mm(1/4”).

Interconnecting wire should be no longer than 500mm (20”) in total length. Wire bending radius should be >100mm (4”). Do not loop or twist interconnecting wire. Failure to meet these requirements will result in higher let-through voltages.

Auxiliary Micro-Switch Installation

Remote signaling is available on all APT DIN products that specify a remote indicator. #16-#30 AWG signal wire may be used. Maximum torque rating for the terminal screw is 1.80 in-lb. The maximum continuous current rating for the remote indicator is 3A.

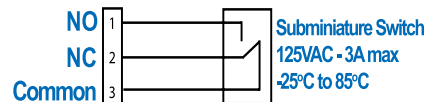
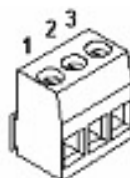

Signal Wire Range: #16 to #30 AWG
Terminal Torque: 1.8lb -in

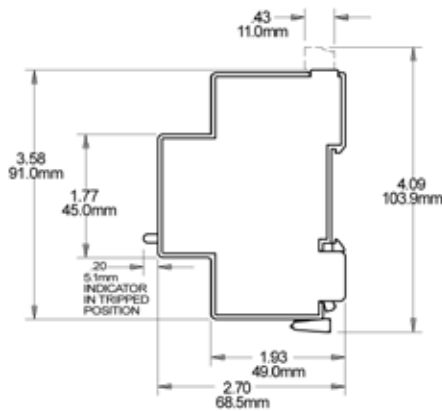
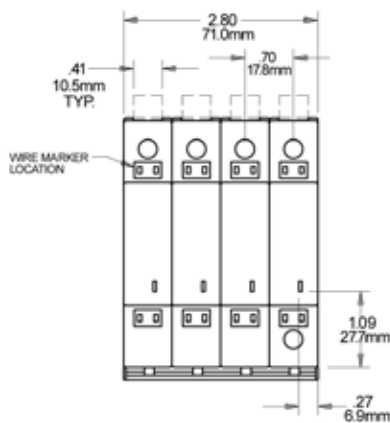

- ** WIRE SIZE: 6-14 AWG
- ** TORQUE: 14.75 LBS-IN
- ** USE 35mm DIN RAIL

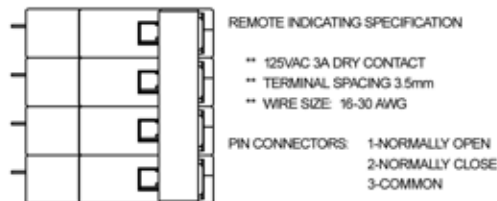

Advanced Protection Technologies



14550 58th Street North
Clearwater, FL 33760
Tel (800) 237-4567
Fax (727) 539-8955
www.apttvss.com