

# P-200E™ System

## Enhancing The Painting Process

### Basic Description

FANUC Robotics' P-200E System is the world's most advanced painting robot system. It combines world-class motion performance with highly integrated application equipment and a user-friendly programming interface. The P-200E, designed for maintainability, is an enhanced version of FANUC Robotics' industry leading paint robot.

Paint waste, color change time and cycle time are reduced by integrating the color changer and flowmeter or gear pump close to the applicator. This provides increased throughput by increased spraying time which improves transfer efficiency. Access to these application components is simple, due to a removable process equipment access cover.

A feasible replacement for manual sprayers, the P-200E System easily handles tough applications including interior cut-ins, exterior and fascia painting. Key advantages for interior cut-in painting are the P-200E System's near reach capability and wrist flexibility.

The P-200E is available with the following mounting configurations: pedestal, clean wall rail and a new modular in-booth rail.

FANUC Robotics is the leader in providing total paint shop automation solutions. Based on experience gained over eight generations of robotic painting designs, the P-200E System delivers a flexible and state-of-the-art painting solution.

### Process Advantages

- Color change valves mounted close to the applicator reduce paint waste and color change time. Shortened paint line



- lengths also permit longer spraying time and higher throughput.
- In-arm hardware and enhanced motion software allow fast “on-the-fly” applicator parameter changes, providing improved paint quality, film build consistency and less paint overspray. This results in reduced costs and higher profit per vehicle or part.
- Options for either in-arm gear pump or an in-arm flowmeter provide fluid delivery flexibility with minimized color change time and material waste.
- Maximized trigger accuracy and repeatability through in-arm trigger valve for fast gun on/off response time.
  - Reduced paint waste
  - Higher film build consistency
  - Accurate path teaching
  - Higher quality
  - Reduced setup and debug time
- Paints entire hood and deck interiors from one body side, which typically reduces number of robots needed.
- Fits into existing booths or greenfield plants, significantly reducing booth construction and operating expenses including airflow and energy costs.
- ACCUFLOW II™ closed-loop fluid delivery system automatically controls fluid flow rates, providing consistent paint delivery and high finish quality.
- Integrated Process Control (IPC) software provides integrated control for single component gear pumps or two-component variable ratio gear pump solutions. The IPC software and servo motor pump control is integrated directly into the robot controller.
- Heavy payload (15 kg at wrist, 15 kg in outer arm) carries current applicators with flexibility for future applicator technology to provide a longer lasting paint shop solution.

**FANUC**  
Robotics

- Enhanced motion software maximizes acceleration and deceleration to improve path accuracy and minimize non-painting time, resulting in reduced cycle and startup/debug time.

### **Motion Control Advantages**

- Extremely fast acceleration and deceleration motion increases spraying time, allowing more area to be covered by the same robot.
- Constant application speed yields consistent film build, providing improved finish appearance.

### **System Control Advantages**

- Easy-to-use PaintWorks™ software provides a Windows™ graphical interface for system programming, operation and maintenance.
- WinTPE and PaintPRO™ PC-based software programs (options) provide simplified, Windows-based programming and program editing interfaces.
- Optional P-10E and P-15E door and hood/decklid openers can be integrated with the P-200E robot to provide interior painting solutions.

### **Installation Advantages**

- P-200E System standard solution is pre-engineered and pretested reducing startup and debug time.
- P-200E robot ships on rail completely integrated, reducing installation time, startup and debug time.
- Extremely large P-200E work envelope increases booth design flexibility by both effectively painting hood and deck interiors from one side of the vehicle and efficiently painting door interiors.
- Integrated process equipment reduces setup/debug time allowing the automation zone to be up and running faster.



**Typical robotic door cut-in applications.**

# Pedestal Robot Dimensions

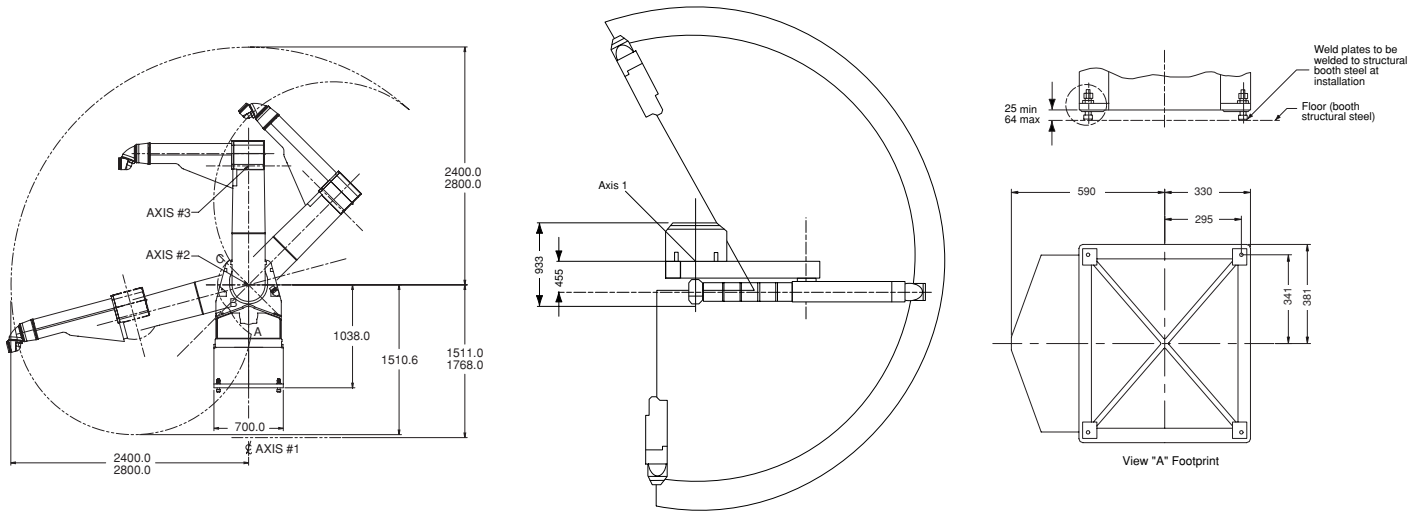

## New Modular In-booth Rail

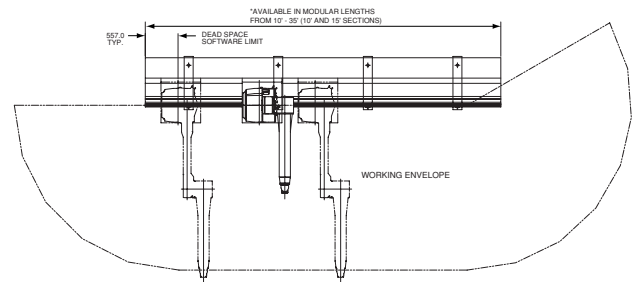
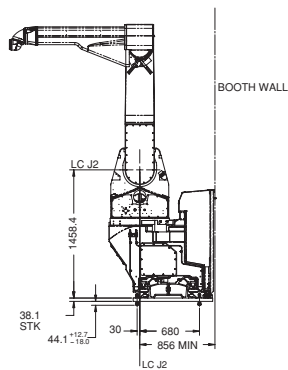

## Wrist

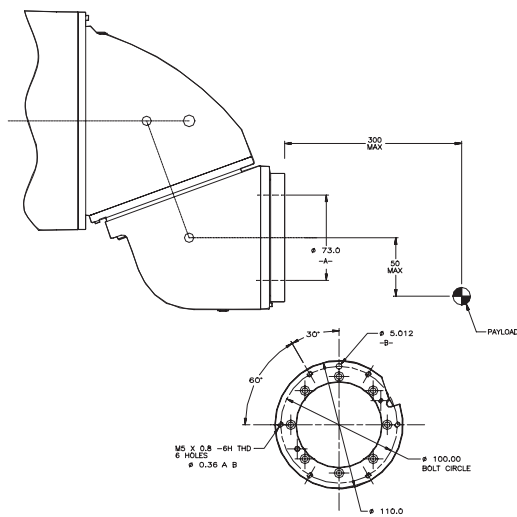

## P-200E Specifications

Items	
Configuration	6-axis vertically articulated 7-axis option
Axes	6 axes (axis 7 optional)
Payload - Wrist (kg)	15 @ 300 mm radial/50 mm axial offset
Outer arm payload (kg)	15 mounted inside of outer arm
Reach (mm)	2800
Static repeatability (mm)	± 0.5
Motion range (degrees)	J1 210 J2 150 J3 160 J4 >360 J5 >360 J6 ± 720 J7 Determined by rail length
Motion speed (degrees/s)	J1 96 J2 119 J3 150 J4 353 J5 429 J6 364 J7 1500 mm/sec
Painting speed	1500 mm/sec
Integrated process equipment	24, 12, 8, 4 color paint system (optional)
Drive type	Electric AC servo motor
Position encoders	Absolute pulse coders
Mastering method	Witness surfaces
Mechanical brakes	Axes 1, 2, 3, 4, 5, 7
Mechanical weight (kg)	523 pedestal robot
Mounting method	Pedestal or rail mount
Installation environment	
Ambient temperature °C	0 to 45
Humidity	20-95%, no condensation
Certification	FM Class, I, II, II/Div. I (Groups C,D,E,F,G)

**Note:** Dimensions are shown in millimeters. Detailed CAD data are available upon request.

## Reliability and Maintenance Advantages

- Removable arm cover and enhanced color valve access provides simplified maintenance for color valves, gear pumps, regulators and other process equipment.
- P-200E can be configured with either a pedestal, modular in-booth rail or a clean wall rail.
- In-arm color changers provide easy access and lower cat track height improves maintenance access.
- Cast aluminum gear boxes contain sealed lubrication that increases reliability and decreases maintenance cost.
- Patented, hollow, sealed wrist and patented purge system for operation in hazardous environments protect motors and cables from painting environment and are approved for Class I, II, and III, Div. 1, Groups C,D,E,F,G T4 Hazardous Locations.
- Internal paint hose routing reduces dirt and minimizes paint line length.

## Integrated Automotive Painting Solution

The P-200E System is a key component in FANUC Robotics' total paint shop automation solution that includes P-500 Bell System and PaintWorks system control. Common technology includes:

- FANUC motion control and FANUC AC servo motors with encoders
- PaintTool, BellTool and RecipTool software packages
- PaintWorks System Control Interface (option)
- WinTPE and PaintPRO graphic programming (option)
- Proven FANUC Robotics' process development, system integration and project management

FANUC Robotics is the market leader in providing total paint shop automation solutions.

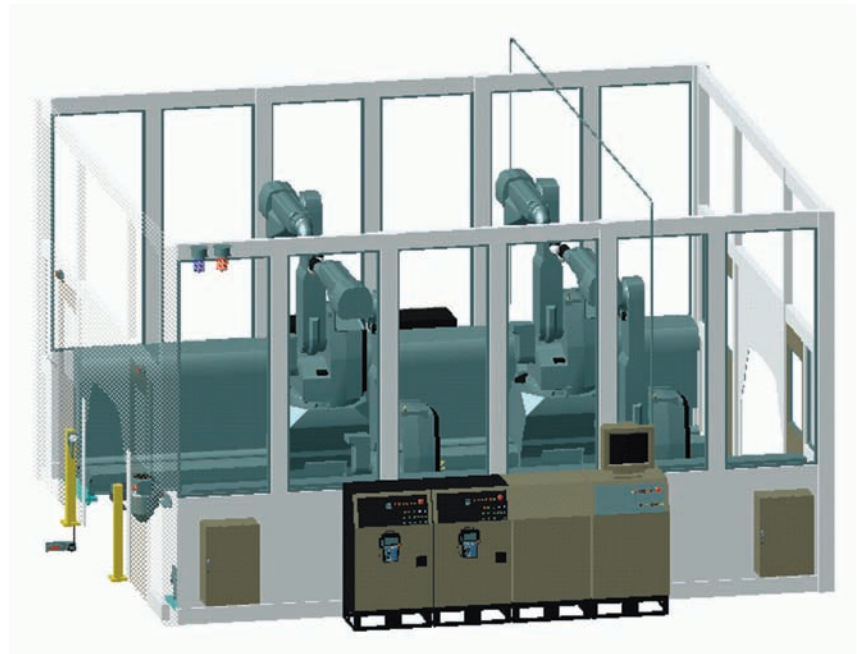

Pre-tested Standard Shippable System

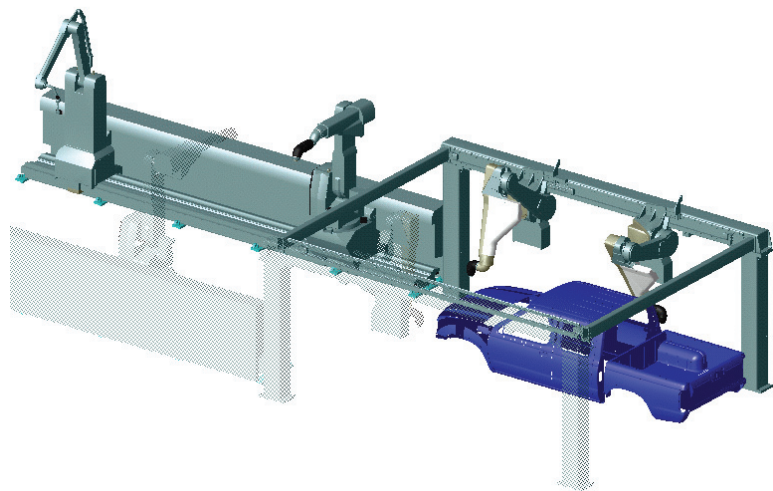

Total Paint Shop Solution

## Intelligent Robot Solutions



**FANUC Robotics America, Inc.**  
**3900 W. Hamlin Road**  
**Rochester Hills, MI 48309-3253**  
**(248) 377-7000**  
**Fax (248) 377-7362**

Charlotte, NC  
 (704) 596-5121  
 Chicago, IL  
 (847) 898-6000

Toronto, Canada  
 (905) 812-2300  
 Montréal, Canada  
 (450) 492-9001

**For sales or technical information, call:**  
**1-800-iQ-ROBOT • 1-800-47-ROBOT**

Cincinnati, OH  
 (513) 754-2400

Aguascalientes, Mexico  
 52 (449) 922-8000

Los Angeles, CA  
 (949) 595-2700

Sao Paulo, Brazil  
 (55) (11) 3619-0599

**marketing@fanucrobotics.com**  
**fanucrobotics.com**

Toledo, OH  
 (419) 866-0788