

## Pro-face AGP/AST3000 to Omron SYSDRIVE JX Series Inverter via Modbus RTU

*Tested, Trusted, Out-of-the-Box*

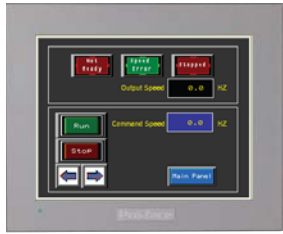

Pro-face AGP3300-T1

Modbus  
Serial Cable



Omron SYSDRIVE  
JX Series Inverter

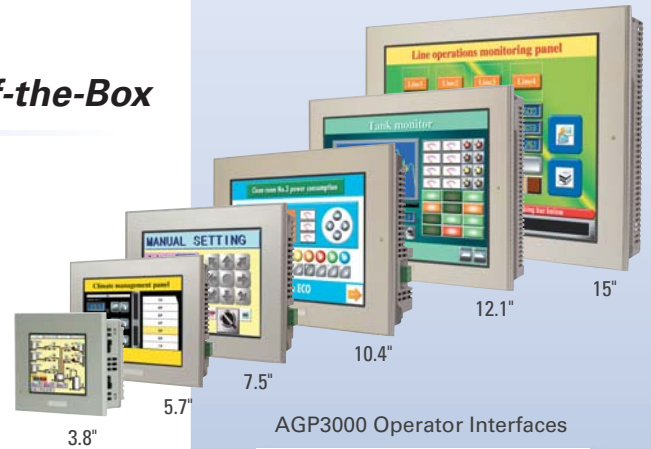

AGP3000 Operator Interfaces



### HMI Motion Quick Start Guides

Pro-face HMI motion control quick start guides make it easy to integrate variable speed drives directly to your operator interface and control system. With minimal knowledge a user can quickly set up a variable speed drive operator interface without requiring a separate programmable controller and drive interface wiring.

#### Differentiating Value:

- Simple, fast installation, 3 step guide with a sample project you can use
- No PLC required, logic controller is built-in
- Reduce system cost, no need for analog interfaces, eliminate pilot lights and push buttons
- Precision high resolution digital control

#### Applications:

- Conveyors
- Pumps and fans
- Packaging equipment
- Discrete manufacturing

These instructions along with the downloadable sample project facilitate quickly connecting and establishing communications between a Pro-face AGP using GP-Pro EX and an Omron SYSDRIVE JX Series Inverter. For a full explanation of this project refer to Pro-face America Application Note 1173.

### Materials:

1. Pro-face GP-Pro EX Screen and Logic Editing software v2.1 or higher
2. Pro-face AGP3000 or AST3000 Series HMI
3. Omron SYSDRIVE JX Series Inverter
4. Pro-face CA3-ADPCOM-01 COM1 or CA4-ADPONL-01 COM2 Port Adapter
5. Pro-face CA3-ADPTRM-01 Termination Adapter
6. CAT5e Ethernet Cable (Straight-Through)
7. The Pro-face sample project "APNT1173.zip" available at <https://www.hmisource.com/otasuke/files/apnotes/>



*Continued on next page*



# Quick Start Guide: Pro-face AGP/AST3000 to Omron SYSDRIVE JX Series Inverter via Modbus RTU



## Easy Configuration

### STEP 1 - Connecting to the Drive

The Omron SYSDRIVE JX Series Inverter communicates using the Modbus RTU protocol via a built-in RJ45 RS485 interface.

Omron SYSDRIVE JX series  
Communications Port (RJ45 Connector)

*Note: only Pins 6 & 5 are used*

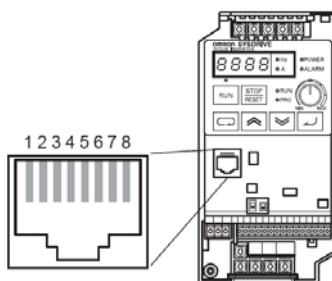

### STEP 1 - Cable Adapters:



CA3-ADPTRM-01



CA3-ADPCOM-01



CA4-ADPONL-01

1. Once the adapter is installed, enable termination, as shown in the instruction manual, for 1:1 connection between the AGP and the Omron Inverter since the inverter will be the last device on the Modbus network.
2. In the enclosed sample project, COM1 on the AGP3300T is connected to the Omron Inverter via RS422/485 2 wire communication. For this reason, the following cable diagram (fig 2a) indicates to use the CA3-ADPCOM-01 adapter. If COM2 will be used in your project, simply substitute the CA4-ADPONL-01 adapter for the CA3-ADPCOM-01 adapter. **These port adapters are not simply gender changers.**

2a - Cable Diagram

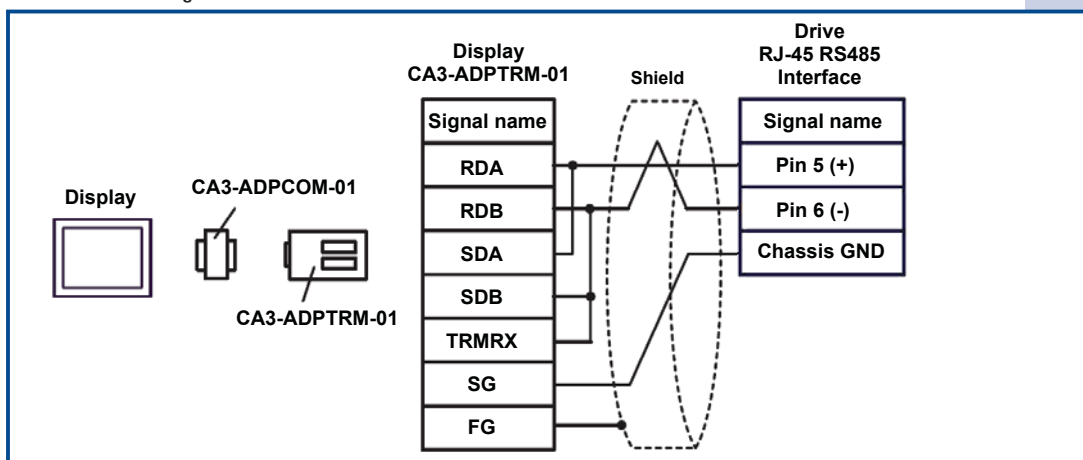

2b - Cable Diagram to build the cable without using the Pro-face adapters

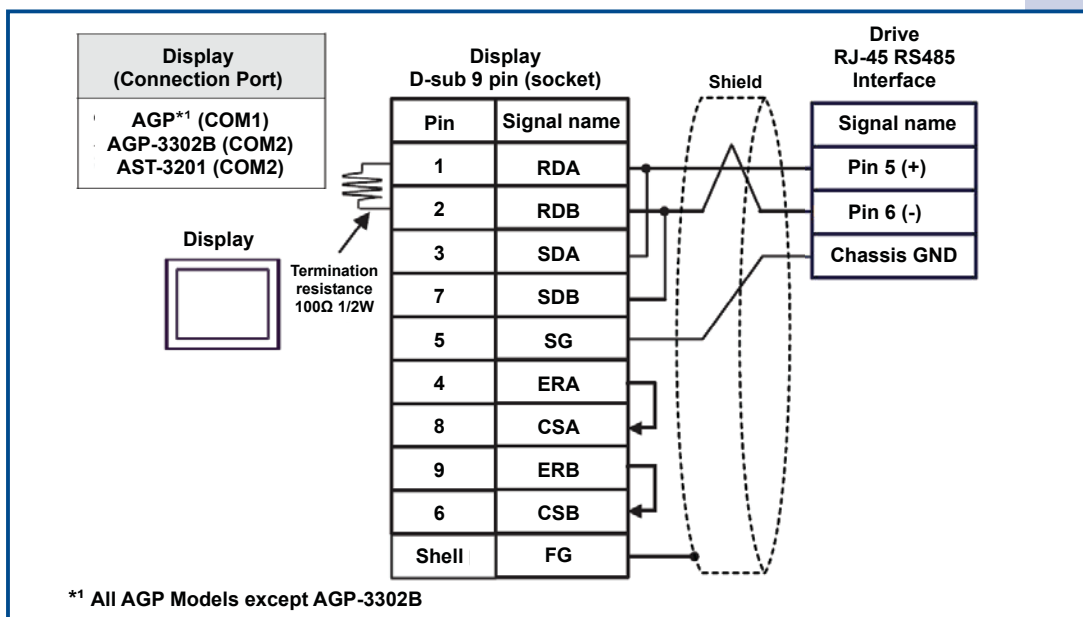

\*1 All AGP Models except AGP-3302B

# Quick Start Guide: Pro-face AGP/AST3000 to Omron SYSDRIVE JX Series Inverter via Modbus RTU



## STEP 2 - Configure the Drive

1. Set up the following drive parameters for use with the sample project as shown in the Omron SYSDRIVE JX Series User's Manual.

- A001 – Frequency Source Selection – 03 (Modbus)
- A002 – Run Command Source Setting – 03 (Modbus)
- C070 – Operator/ModBus selection – 03 (Modbus)
- C071 – Communication Speed – 06 (19,200bps)
- C072 – Modbus Network (Slave) Address – 1
- C074 – Communication Parity – 00 (No Parity)
- C075 – Stop Bits – 1
- C078 – Communication Wait Time – 4 (milliseconds)

2. Once the drive parameters are completely configured on the Omron Inverter, set it to accept commands via the RS422\485 network using the OPE/485 switch. Power off the inverter and move the switch to the “485” position.

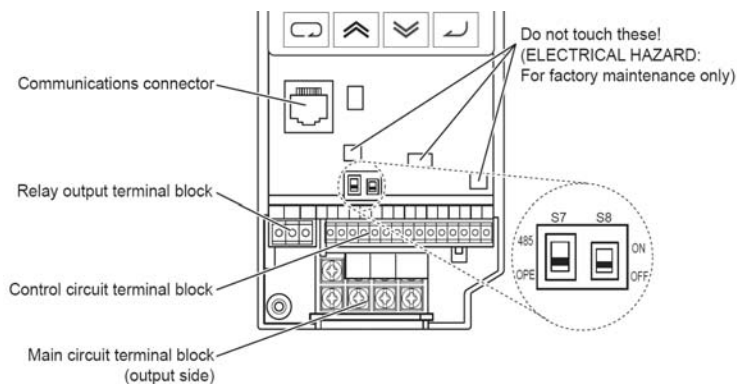

Project Screen:

## STEP 3 - Configure the Operator Interface

The sample project is already configured for an AGP3300. Simply download the project to the operator interface. When the download is complete press “Operator Panel” to view drive status and operate the drive.

### Using a Different Model AGP/AST/LT3xxx:

The following models of the Pro-face 3000 series can be used with this sample project:

| Panel Size | Series  | Class/Type |                 |            |           |
|------------|---------|------------|-----------------|------------|-----------|
|            |         | Standard   | Control         | Multimedia | Hand-held |
| All        | AGP3xxx | ✓          | ✓               | ✓          | ✓         |
| All        | AST3xxx | ✓          | ✗               | ✗          | ✗         |
| All        | LT33xx  | ✗          | ✓ <sup>*1</sup> | ✗          | ✗         |

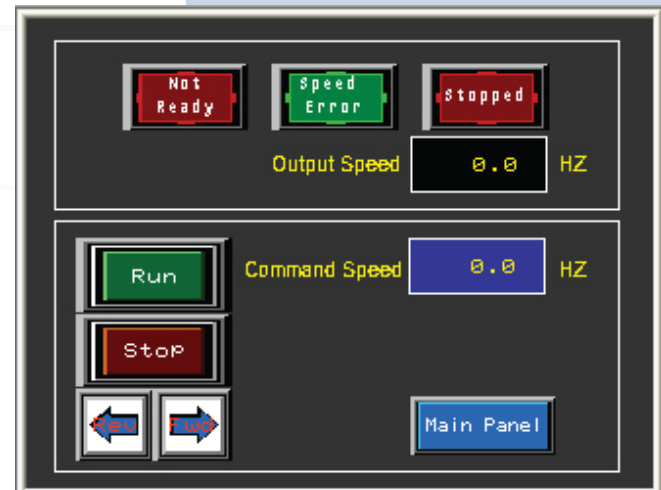

The sample project is configured for an AGP3300T. To use the project with a different model AGP and screen size, follow these steps:

1. Open the enclosed GP-Pro EX project, click “Project (F)” then “System Settings (C)”.
2. Click on “Display” in the System Settings menu then “Change Display Unit”.
3. Select the series line and model of your AGP. If the “Convert Resolution” prompt appears, check the box to automatically resize all screen objects in the application.
4. Click “OK” to the reminder to check the screen objects before downloading to an AGP.
5. Click “YES” to acknowledge that AGP models have hardware capabilities.
6. Save the project to a new file.

Note: <sup>\*1</sup>To use the sample project with a LT33xx: Open the project in GP-Pro EX. Open another instance of GP-Pro EX and select the LT33xx model you are using. Copy the desired screens and the global script from the first instance to the second.

# Quick Start Guide: Pro-face AGP/AST3000 to Omron SYSDRIVE JX Series Inverter via Modbus RTU

# Pro-face

## Download the Project:

The sample project includes a screen "Operator Panel" (B20). It includes common operator interface controls on a single screen for your convenience. All other screens in this project can be deleted.

---

750 North Maple Road • Saline, MI 48176 USA  
Tel: 734-429-4971 • Toll Free: 800-289-9266  
<http://www.profaceamerica.com>  
E-mail: [sales@profaceamerica.com](mailto:sales@profaceamerica.com)

# Pro-face

